



HexaLux™  
EXAMINATION LIGHT



 STERIS



*The light...*  
Essential. Everywhere.

Examination light



With 14,000 employees worldwide, **STERIS** is a major player in the healthcare sector. With over 25,000 partner-customers in more than 80 countries, **STERIS** covers all operating theatre needs and proposes **ORigami™**, a complete solution: operating tables, surgical lighting, distribution arms, integration systems, etc. Everything is designed, coordinated and optimised to offer exceptionally high-quality everyday service.

**STERIS** also supplies technologies that contribute to preventing infections: **STERIS IPT** (*Infection Prevention Technology*), washers, disinfection units, sterilisers, and consumables.



### Lighting made in France

**HexaLux™** is distributed worldwide and made in France, at a site that produces a wide range of operating theatre equipment. This choice enables us to offer products of maximum quality, both in industrial and environmental terms:

- Proximity and integration of the specific needs of French and European users
- Full control of industrial processes
- Integration of the best European suppliers giving preference to local suppliers
- Reduced ecological footprint



*STERIS products are developed and manufactured in an environmentally sustainable manner, focusing on sustainable development.*

More now than ever, our values of integrity, team spirit, results orientation, along with our predilection for the constant improvement of our products and processes, represent our future.

We enhance safety, the environment, integrity and mutual respect, by supporting our employees, Customers and patients in compliance with all applicable regulations.



*Production unit of our surgical lights  
(Le Haillan, France)*



## New generation examination lights

**An operating theatre specialist in the service of the whole hospital!**

Good lighting facilitates your routine activities: diagnostic security, patient safety, reduced eye strain...

**STERIS**, an operating theatre equipment specialist, makes its ergonomic and versatile examination lighting available to all practitioners: **HexaLux™**.

**HexaLux™** combines operating theatre-derived high-level technologies with disconcerting ease of use. These assets make it the ideal lighting for a broad range of medical applications.

### **HexaLux™, developed by STERIS**

At **STERIS**, pragmatism is at the heart of all innovation. All product development is driven by actual user needs.

*Our credo: useful innovation*



**Versatile, HexaLux™ makes itself essential everywhere!**

**HexaLux™** is suitable for a broad range of applications:

- Examination rooms
- Emergency rooms
- Plaster rooms
- Intensive care units
- Reanimations units
- Minor surgery
- Induction and recovery rooms
- Neonatal units
- Paediatric departments
- Maternity ward
- Morgue

## Exceptional lighting quality



### High-quality materials

The expertise of **STERIS** for surgical lighting design in the service of examination lights: **HexaLux™** is designed from high-quality materials, guaranteeing constant performance, whatever the application (small wounds, sutures, clinical examination, diagnostics, etc.).



### Aluminium light head and yoke

The **HexaLux™**, cast aluminium light head and yoke are both robust and light, offering great comfort of use. Its excellent heat dissipation properties enable to maintain lighting performance over time.



### First grade LEDs and superior optical qualities

**HexaLux™** examination light generates homogeneous white light (4400 K), offering excellent colour restitution ( $R_a = 95$ ), in particular for Caucasian skin tone ( $R_{13} = 97$ ) and red tones ( $R_9 = 97$ ). Your diagnostics will benefit from its reliability. Its service life of more than 50,000 hours is compatible with the needs of daily use.



### SUITABLE FOR DAILY USE

Examination lights take quite a battering. Moved, folded away, constantly handled, it is put to severe test. **HexaLux™** is a robust examination lighting system, designed to withstand intensive daily use.

## Intuitive to use

### One-Click control

To simplify its use, all **HexaLux™** features are directly available from the central handle:

- Turn the light on or off
- Adjust the light intensity
- Adjust the light spot size

*" One-click control " a unique asset Adjustable and easy handling with one hand: HexaLux™ allows to focus on the essential: the patient*



The handle can be sterilised, thus enabling its use for minor surgical procedures.

*Adjustements are very intuitive: simply rotate the handle!*



### Thank to its design,

**HexaLux™** light head is very easy to handle:

- Triangular shape allowing it to be gripped anywhere
- 360° light head rotation to meet all viewing needs
- Two side handles providing a secure and comfortable grip







## One light, several configurations

HexaLux™ is available in three configurations to adapt to all types of applications: wall-mounted, ceiling-mounted or mobile stand.

# HexaLux™

EXAMINATION LIGHT

## Ceiling-mounted Version

The examination light HexaLux™ ceiling-mounted can be adapted to various ceiling heights. It covers a large radial area, thus offering great freedom of movement and allowing to be moved close to the area to examine.



# HexaLux™

EXAMINATION LIGHT

## Wall-mounted Version

The examination light HexaLux™ wall-mounted simultaneously offers great span to provide close-up lighting and can also be folded back when not in use, thus freeing up space.



# HexaLux™

EXAMINATION LIGHT

## Mobile Versions

The mobile versions enable ambulatory use suitable for various applications. The mobile version with built-in batteries offers great autonomy. A wide range of accessories is available, offering even more practical solutions for your clinical environment.

### Easy to carry

- Up to 6.5 hours' autonomy thanks to the optional batteries
- Highly manoeuvrable thanks to its 5 swivel castors with brake
- Hook to attach the cable if used without a retractable power cord reel

### Practical

- Shelf and basket allow to keep the patient's record, accessories, dressings, etc. to hand

### Stable and compact

- Small footprint
- Maximum base stability
- Automatic cable reel (optional): eliminates cables on the floor
- Folding mast for reduced storage dimensions



Mobile version with optional batteries, retractable power cord reel, basket and shelf

# An operating theatre specialist in the service of the whole hospital!



Intensive care units



Examination rooms



Maternity ward



Consultation rooms



Minor surgery

Versatile,  
**HexaLux™**  
makes itself essential everywhere!



**Easy to clean and sterilise**

- Sterilisable handle, easy to clip on and off
- Smooth base, easy to clean



# Technical characteristics

## HexaLux™ EXAMINATION LIGHT Wall-mounted Version

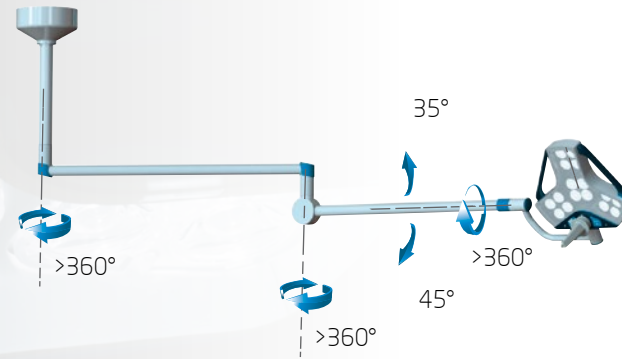
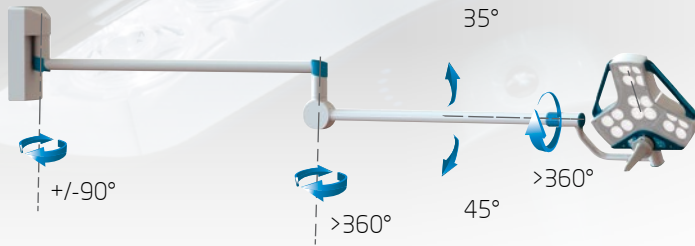

## HexaLux™ EXAMINATION LIGHT Ceiling-mounted Version



## HexaLux™ EXAMINATION LIGHT Mobile Versions

Characteristics	HexaLux™
Light intensity (E <sub>c</sub> ) in Lux*	10 000 à 65 000
Colour temperature (Kelvin)	4 400
Colour rendering index Ra	95
Red rendering R9	97
Caucasian skin colour rendering R13	97
Light field diameter (cm)*	14 à 20,5

\*Measurements made between 0.85 m and 1 m

The HexaLux™ examination lighting system is a Class I medical device. To use this equipment safely, carefully read the instructions in the user manual and on the labelling.



# STERIS

## STERIS OFFICES WORLDWIDE

Belgium + 32 304 95 44  
Canada + 905 677 0863  
China + 86 10 5900 3786  
France + 33 5 56 93 94 94  
Germany + 49 221 4661 20 30  
India + 91 33 2367 5150  
Italy + 39 02 213 034 1  
Latin America + 55 11 3372 9499  
Malaysia + 60 3 7954 9822  
Russia + 7 499 737 7733  
Singapore + 65 68 41 7677  
Spain + 34 91 658 5920

## STERIS SAS

116 Avenue de Magudas  
33185 Le Haillan - France  
Tel: + 33 5 56 93 94 94  
Fax: + 33 5 56 93 94 95  
Email: [contact\\_hc@steris.com](mailto:contact_hc@steris.com)  
[www.steris-healthcare.com](http://www.steris-healthcare.com)  
[www.steris-accessoires.com](http://www.steris-accessoires.com)

## STERIS Corporation

5960 Heisley Road - Mentor,  
OH 44060-1834 - USA  
Tel: + 1 440-354-2600  
Fax: + 440-639-4457  
[www.steris.com](http://www.steris.com)

## ESCHMANN Equipement

A Subsidiary of STERIS Corporation  
Eschmann House  
15 Peter Road  
Lancing Business Park  
Lancing, West Sussex BN15 8TJ  
Tel: + 44 1903 753322  
Fax: + 44 1903 875789  
Email: [info@eschmann.co.uk](mailto:info@eschmann.co.uk)  
[www.eschmann.co.uk](http://www.eschmann.co.uk)

# ESSENTIAL. EVERYWHERE.